

Quick Start Guide for Precision Microwave Coaxial Connections

You will use only SMA connectors in the EE481/692 laboratory. Do NOT finger tighten these, or any other, precision microwave connections. Instead, use the black-handled torque wrench, which provides the proper 5 in-lbs of torque required for SMA connectors.



If you over-torque a connection, it is possible you will damage the connector on the vector network analyzer, the cable or your microwave circuit. There may be different types of torque wrenches lying about the lab. Be certain that you are using the **BLACK** colored torque wrench.

- 1) When initially making a microwave coaxial connection:
 - Make sure you have the electrostatic wrist-strap on and that it is properly grounded.
 - Be certain there are no metal filings or other debris inside the connectors.
 - Line up the connectors before threading. You will likely find out that it is not uncommon for the internal connections to be unaligned as you start the threading.
 - Do not bend or twist the flexible cables more than necessary.
 - Hand-tighten the connectors to the point where you first feel resistance.

NOTE: If you feel resistance prematurely, it is likely the connectors are not properly aligned. Simply undo the connection and try again. Forcing the connection may lead to damage.

- 2) To tighten a microwave coaxial connection:
 - You will need two tools to tighten the connectors. One is a precision torque wrench for tightening and the other is a regular open-ended wrench for resistance. Place the torque wrench on the connector you wish to tighten with the "knee" pointing in the direction you wish to tighten. Use the open-end wrench on the other connector to hold the connection as you tighten.
 - Hold the torque wrench near or above the line at the end of the handle. Slowly tighten the connection with the torque wrench and to the point where the wrench **begins** to bend. Do not let the torque wrench bend more than approximately 45°. Notice after a certain threshold the wrench will move quickly with a snapping action.
 - Always fully tighten the connection with the torque wrench.
- 3) To loosen a microwave coaxial connection:
 - Make sure that you are loosening the connection and not tightening it further. In fact, you should use the torque wrench as a check that you are turning in the correct direction.
 - Use the same care in loosening as when tightening.

SMA and APC3.5 Connectors

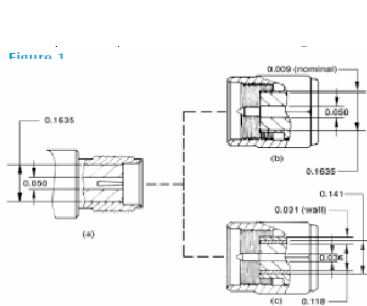

Figure 1: The single SMA female configuration (a) can mate with both the "conventional" male (b), and the "thru" male (c).

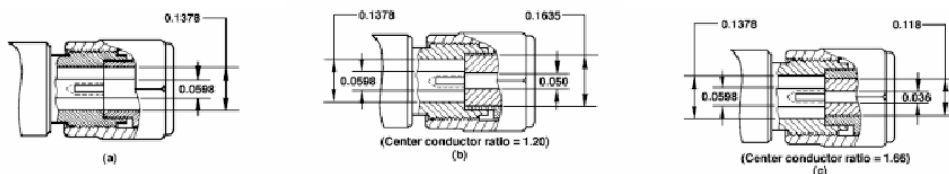
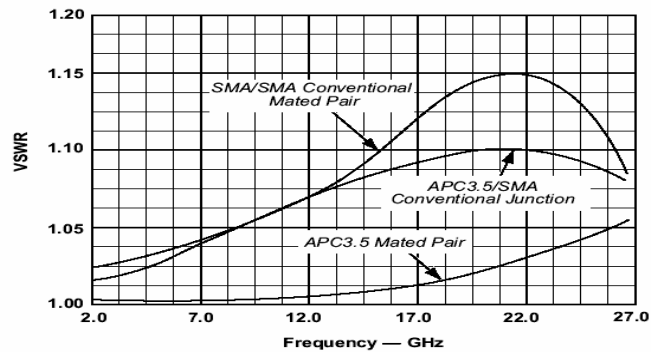

Figure 3: An APC3.5 mated pair (a) provides a precision junction with no discontinuities. Line size discontinuities are apparent when the APC3.5 mates to a "conventional" SMA connector (b), and are more of a problem with the SMA "thru" male (c).

The SMA connector was originally developed in 1958 to extend the range of usable frequencies for coaxial cables up to 18 GHz. Cross-sectional diagrams of this connector are shown in Fig. 1. For systems applications, SMA is the most widely used microwave connector today. It is the only connector you will be using in the EE481/692 laboratory. The SMA connector is user friendly, economical and miniature sized. While the performance of SMA connectors is good for system-wide applications, laboratory measurements sometimes require a higher level of performance.

The need to improve the SMA connector led to the development of the APC3.5 mm connector (see Fig. 3 above). SMA and APC3.5 connectors are mechanically similar and can be interconnected. Inside the connectors, however, SMA has a dielectric interface while the APC3.5 is an air-interfaced connector. Proper gauging is a common problem when using SMA connectors, which can lead to damage of the connectors and unsatisfactory reflections at these junctions. As expected, using only APC3.5 connectors will yield the best performance, but the connectors are significantly more expensive than SMA. A combination of SMA and APC3.5 has been shown to provide increased electrical performance over strictly SMA connectors (see the "VSWR vs. Frequency" illustration shown above). APC3.5 connectors are less prone to mechanical damage and more exact gauging is achieved due to the air interface. This can produce measurements that are more consistent. The walls of the APC3.5 and the "thru" SMA connector are robust, but they will better withstand wear and damage when using the proper torque wrench for tightening. A torque wrench will increase accuracy, repeatability and reliability when performing measurements.

Proper connection is critical when tightening coaxial connectors. In fact, torque wrenches have been specifically designed for this purpose alone. Each is specified for a particular amount of torque and they will "break" once this torque threshold has been applied.